

**pasquali**

M A D E I N I T A L Y



# MODEL YEAR 24

# NUOVA GAMMA 85 MODEL YEAR 24

 VERSIONI DISPONIBILI  
AVAILABLE VERSIONS  
AR - RS - DUALSTEER® - MT

 TRASMISSIONE  
TRANSMISSION  
16 + 16

 POTENZA  
POWER  
75 hp

 CAP. SOLLEVATORE POST.  
REAR LIFT CAPACITY  
2300 kg

 POSTO DI GUIDA  
DRIVING POSITION  
Reversibile / Reversible

**NEW  
RANGE 85  
MODEL  
YEAR  
24**





## COMFORT ASSOLUTO

Migliore ergonomia del posto guida, spazio abitativo aumentato e maggiore comfort per il conducente, sia con guida standard che retroversa!

- Maggiore corsa del sedile
- Accesso al posto guida più agevole con maggiore spazio per oltrepassare il tunnel
- Pedali in posizione più avanzata
- Tutti pedali sospesi, incluso l'acceleratore
- Nuova plancia cruscotto
- Nuovo comando dell'acceleratore manuale a pomello
- Aggiunta coppia di prese USB
- Ventola Self Cleaning System™ con portata maggiorata



## ABSOLUTE COMFORT



*Improved ergonomics of the driver's seat, increased living space and greater comfort for the driver, both with standard and reverse driving position!*

- *Increased seat travel adjustment*
- *Easier access to the driver's seat with more space to pass over the tunnel*
- *Pedals in a more forward position*
- *All suspended pedals, including throttle*
- *New dashboard*
- *New manual throttle control with knob*
- *A pair of USB sockets has been added*
- *Self Cleaning System™ fan with increased flow*



## ATTACCO ATTREZZI

- Puntone tirante 3° punto meccanico e idraulico provvisti di braccetto di fissaggio
- Protezione apribile del codolo PTO
- Nuovo tirante verticale per bracci telescopici



## IMPLEMENT HITCH



- *Mechanically and hydraulically controlled upper link and third point tie rod link arm equipped with fixing arm*
- *Opening guard of the PTO tang*
- *New vertical tie rod for telescopic arms*

## UPGRADE IDRAULICO

Migliorata l'offerta idraulica e la performance di raffreddamento dell'olio idraulico!

- Nuovo circuito di raffreddamento
- Aggiunto filtro spin-on in pressione su tutti gli allestimenti
- Posizionamento delle prese idrauliche posteriori sui parafanghi, anche nelle versioni RS e Dualsteer (non disponibile con cabina 'Space Klima' a 6 montanti)
- Nuova impugnatura joystick
- Distributore flottante anche con joystick
- Aggiunto un secondo Scarico Libero (3/8")
- Antidumping disponibile anche nelle versioni con joystick e sforzo controllato



## HYDRAULIC UPGRADE

*Improved hydraulic supply and hydraulic oil cooling performance!*

- *New cooling circuit*
- *Pressure spin-on filter on all fittings has been added*
- *Positioning of the rear hydraulic outlets on the fenders, also on RS and Dualsteer versions (not available with 6-post frame 'Space Klima' cab)*
- *New joystick handle*
- *Control valve with float also with joystick*
- *A second free flow oil return (3/8") has been added*
- *Anti-dumping also available on versions with joystick and rear hydraulic lift with position and draft control*

## CABINA CAT. 4

Nuova cabina conica a 4 montanti "Vista Pro"!

- Pressurizzata e omologata in categoria 4
- Fari di lavoro LED sui quattro lati della cabina per un totale di 10 LED
- Tetto in sintonia con il colore della carrozzeria
- Autoradio USB con vivavoce e diffusori acustici di serie



## CAT. 4 CABIN

*New conical 4-post frame cabin "Vista Pro"!*

- *Pressurized and approved in Category 4*
- *LED working lights on the four sides of the cab for a total of 10 LEDs*
- *Roof in tune with body color*
- *USB car radio with speakerphone and loudspeakers as standard*

## LOOK

- Fanaleria full LED con nuovi portafari
- Nuovo design del volante
- Cabina Space Klima rinnovata con montanti laterali in sintonia con il colore della carrozzeria, lampada rotante e fari posteriori LED



## LOOK

- *Full LED lights with new headlights*
- *New steering wheel design*
- *Space Klima cab renewed with side pillars in tune with body color, LED beacon lamp and rear lights*

# GAMMA 85 - MODEL YEAR 24

## RANGE 85 - MODEL YEAR 24

### MOTORE / ENGINE

KOHLER, 4 cilindri, Turbo Common Rail <i>Kohler, 4 cylinders, Turbo Common rail</i>	
CILINDRATA <i>DISPLACEMENT</i>	2482 cc
POTENZA <i>POWER</i>	55,4 kW / 75,3 hp @2300 rpm
COPPIA MOTRICE MAX <i>MAX TORQUE</i>	300 Nm @1500 rpm

### DATI TECNICI / TECHNICAL DATA



TRASMISSIONE <i>TRANSMISSION</i>	Cambio sincronizzato 16 AV + 16 RM con frizione Easy Plus™ <sup>(1)</sup> e funzione Smart Brake & Go <sup>(2)</sup>	<i>Synchronised gearbox 16 FWD+ 16 REV with Easy Plus™ clutch<sup>(1)</sup> and Smart Brake &amp; Go<sup>(2)</sup></i>
INVERSORE SINCRONIZZATO <i>SYNCHRONISED REVERSER</i>	Sì, con pulsante Power Clutch System <sup>(3)</sup>	<i>Yes, with Power Clutch System button<sup>(3)</sup></i>
FRIZIONE <i>CLUTCH</i>	A dischi multipli in bagno d'olio a gestione elettronica	<i>Multidisc in oil bath with electronically-managed</i>
TELAIO <i>CHASSIS</i>	Integrale oscillante OS-Frame	<i>Swinging integral OS-FRAME</i>
TRAZIONE <i>DRIVE</i>	4WD con disinserimento della trazione anteriore	<i>4WD with front-wheel drive disengagement</i>
PTO POSTERIORE <i>REAR PTO</i>	540/540E rpm (540/1000 rpm su MT), indipendente e sincronizzata	<i>540/540E rpm (540/1000 rpm for MT), independent and synchronised</i>
IMPIANTO IDRAULICO <i>HYDRAULIC SYSTEM</i>	A doppio circuito con pompe indipendenti e scambiatore di calore, fino a 12 prese idrauliche posteriori	<i>Dual circuit with independent pumps and heat exchanger, up to 12 rear hydraulic outlets</i>
SOLLEVATORE POSTERIORE <i>REAR LIFT</i>	Alza e abbassa, a due cilindri esterni	<i>Raising/lowering, by two external cylinders</i>
CAPACITÀ SOLLEVATORE POST. <i>LIFTING CAPACITY</i>	2300 kg (alle rotule)	<i>2300 kg (at the ball joint)</i>
FRENI DI SERVIZIO <i>SERVICE BRAKES</i>	A dischi in bagno d'olio con comando idrostatico, agenti sulle 4 ruote	<i>Oil bath discs with hydrostatic control, acting on the four wheels</i>
POSTAZIONE DI GUIDA <i>DRIVING POSITION</i>	Piattaforma rotante sospesa su silent-block e pedali sospesi	<i>Reversible with rotating platform suspended on silent blocks and suspended pedals</i>
CABINA <i>CABIN</i>	In opzione. 'Vista Pro' conica a 4 montanti pressurizzata e omologata Cat. 4 o 'Space Clima' a 6 montanti	<i>Optional. 'Vista Pro' 4-upright conical structure, pressurised and homologated cat. 4 or 'Space Clima' 6-upright</i>
PRINCIPALI OPTIONAL <i>MAIN OPTIONS</i>	Inversore elettroidraulico EasyDrive®, joystick, sollevatore anteriore, sollevatore posteriore a posizione e sforzo controllato, sospensione idraulica HDR con accumulatore, sistema anti-dumping, Self Cleaning System™, bumper anteriore, zavorre anteriori e zavorre per ruote	<i>Electro-hydraulic power shuttle EasyDrive®, joystick, front lift, rear lift with position and draft control, HDR hydraulic suspension with accumulator, anti-dumping system, Self Cleaning System™, front bumper, front weights and wheel weights</i>

<sup>(1)</sup> Assistenza all'uso della frizione tramite software per innesti sempre progressivi e senza strappi.

<sup>(2)</sup> Consente di arrestare il trattore e ripartire agendo solamente sul pedale del freno, senza usare la frizione.

<sup>(3)</sup> Pulsante per l'innesto delle marce e dell'inversore senza l'utilizzo del pedale della frizione.

<sup>(1)</sup> The clutch is controlled by a software for always smooth and progressive engagements.

<sup>(2)</sup> It allows to stop the tractor and restart by acting only on the brake pedal without using the clutch.

<sup>(3)</sup> Button for engaging gears and reverser without using the clutch pedal.

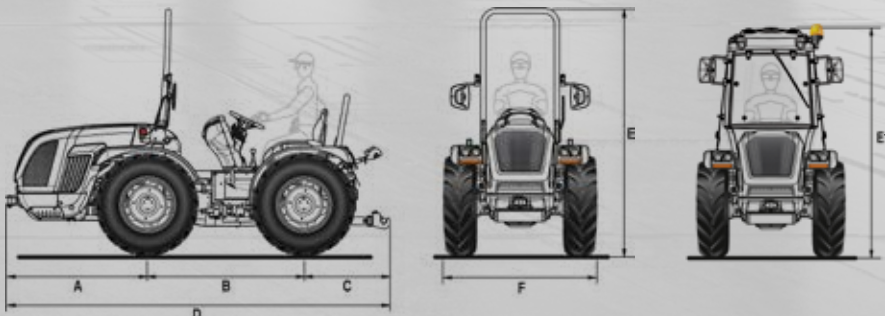

	A	B	C	D	E (con arco) (with roll-bar)	E1 (con cabina Vista) (with Vista cab)	E2 (con cabina Space) (with Space cab)	F	PESO / WEIGHT (arco/cabina) (roll-bar/cab)
AR	1365	1495	930	3790	2254 / 2364	2139 / 2249	-	1127 / 1603	2240 / 2390
RS	1365	1495	930	3790	2254 / 2364	2139 / 2249	2070 / 2180	1291 / 1961	2320 / 2470
DS <sup>®</sup>	1365	1495	930	3790	2254 / 2364	2139 / 2249	-	1291 / 1961	2390 / 2540
MT	1365	1495	930	3790	-	-	2070 / 2180	1697 / 1961	2500

Dimensioni in mm (min / max) - Peso in kg  
Dimensions in mm (min / max) - Weight in kg